



2141 ICON Way, Suite 100, Vacaville, CA 95688 - Tel: 707.564.4000 – www.iconaircraft.com

# SERVICE BULLETIN

## SB-101722-D

**ID NUMBER & REVISION:** SB-101722-D  
**SUBJECT:** Canopy Latch Installation  
**RELEASE DATE:** 19 August 2024  
**EFFECTIVE DATE:** 19 August 2024  
**SUPERSEDES NOTICE:** SB-101722-C  
**AIRCRAFT AFFECTED:** **MAKE & MODEL:** ICON A5  
**SERIAL NUMBERS:** ASN: 00130 – 00153; 00155; 00156; 00158 – 00166  
**REQUIRED ACTION:** Inspect the canopy latch mechanism for proper torque and installation. Adjust the canopy latch mechanism if torque specifications are not met.  
**TIME OF COMPLIANCE:** At the next Service Interval or if the canopy latch opens during flight.  
**REVISION HISTORY:**  
**A** Initial Release  
**B** Updated the affected aircraft  
**C** Added ASN 00155 to the affected aircraft  
**D** Changed sealant application over latch screws from Silpoxy to A-85 by referencing SL-072224. Changed notes regarding sealant removal/application to steps. Changed torque from 26 in-lb to 25-28 in-lb. Revised Service Bulletin form to Revision G.

**LEVEL OF CERTIFICATION**       Pilot/Owner       A & P  
**REQUIRED (any level checked**       LSA Repairman – Inspection       Certified Repair Station  
**can perform task):**       LSA Repairman – Maintenance       Manufacturer

**PURPOSE:**

ICON has identified a situation where the canopy latch mechanism would not remain closed during flight. In addition, the canopy latch mechanism could be opened with less than the required amount of force per ICON specifications. The intent of this service bulletin is to provide guidance for the inspection of the canopy latch and adjustment to the canopy latch mechanism.

**ASSEMBLIES AND PARTS:**

PART NUMBER	DESCRIPTION	QUANTITY	ALTERNATE	
			PART NUMBER	DESCRIPTION
N/A	Powder Free Nitrile Gloves	A/R		
N/A	Powder Free Latex Gloves	A/R		
N/A	Isopropyl Alcohol	A/R		
MS16624-4075	Retaining Ring	1 (As Needed)		
ICA014544	Wave Spring	1 (As Needed)		
ITL002660	Torque Wrench Adapter	1		
LOCTITE 243	Loctite 243	A/R		

# SERVICE BULLETIN

## SB-101722-D

### IF APPLICABLE, SERVICE KITS:

KIT NUMBER	CONTENT PARTS	DESCRIPTION	QUANTITY
N/A			

### INSTRUCTIONS:

It is permissible to disassemble the aircraft as required to permit accessibility, inspection, adjustment, maintenance, and repair in accordance with the latest release of the ICON Aircraft Maintenance Manual.

It is also permissible to retain and reuse any serviceable parts and hardware.

### Latch Strike Plate Inspection/Repair

1. Lift the canopy up and out of the way
2. Loosen the two bolts on the back of the strike plate
  - a. See Figure 1

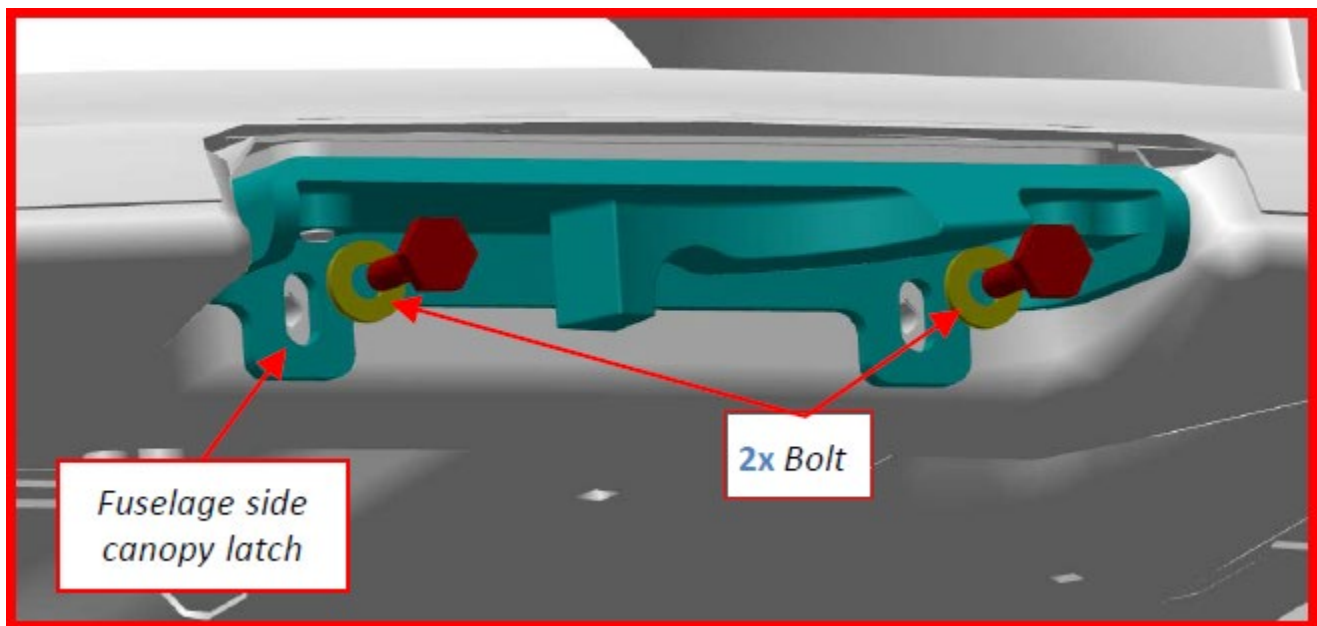
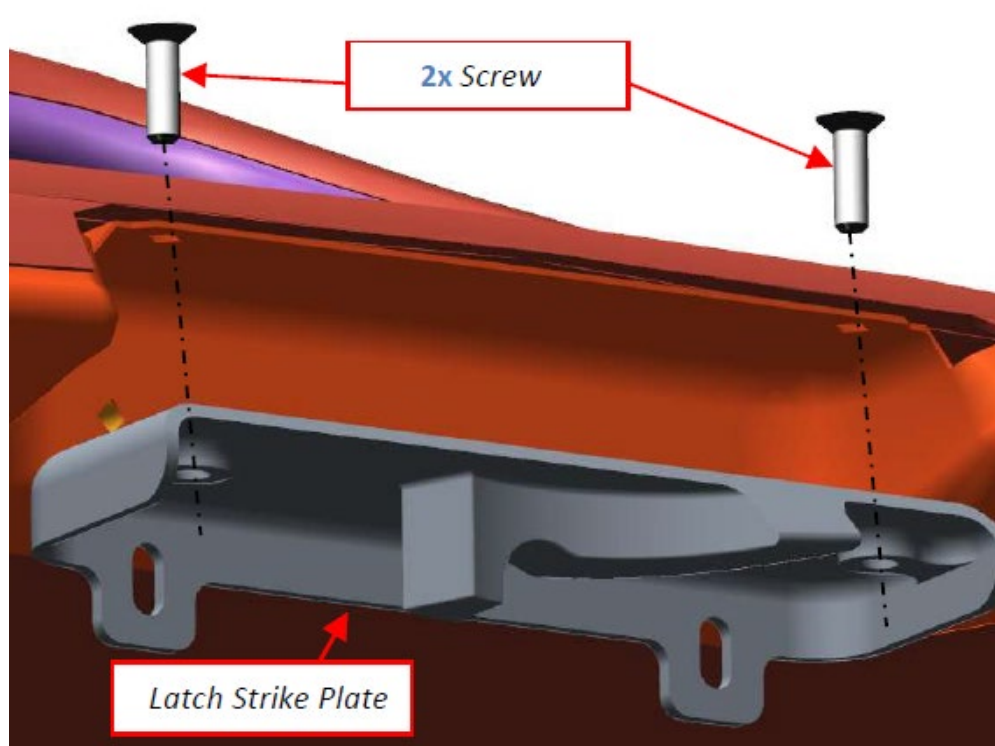

Figure 1 Bolts and Back of Strike Plate

3. Inspect the two screws on top of the strike plate
  - a. Remove sealant over screw heads, if present.
  - b. Verify the two screws are torqued to 25-28 in-lb.
  - c. See Figure 2

**SERVICE BULLETIN****SB-101722-D***Figure 2 Screws on Top of Strike Plate*

4. Torque the two bolts on back of the strike plate (Figure 1) to 25-28 in-lb.

**Interior Canopy Handle Removal**

1. Sitting in the cockpit with canopy closed, remove the interior canopy latch handle by removing the set screw
  - a. See Figure 3

**SERVICE BULLETIN**

SB-101722-D

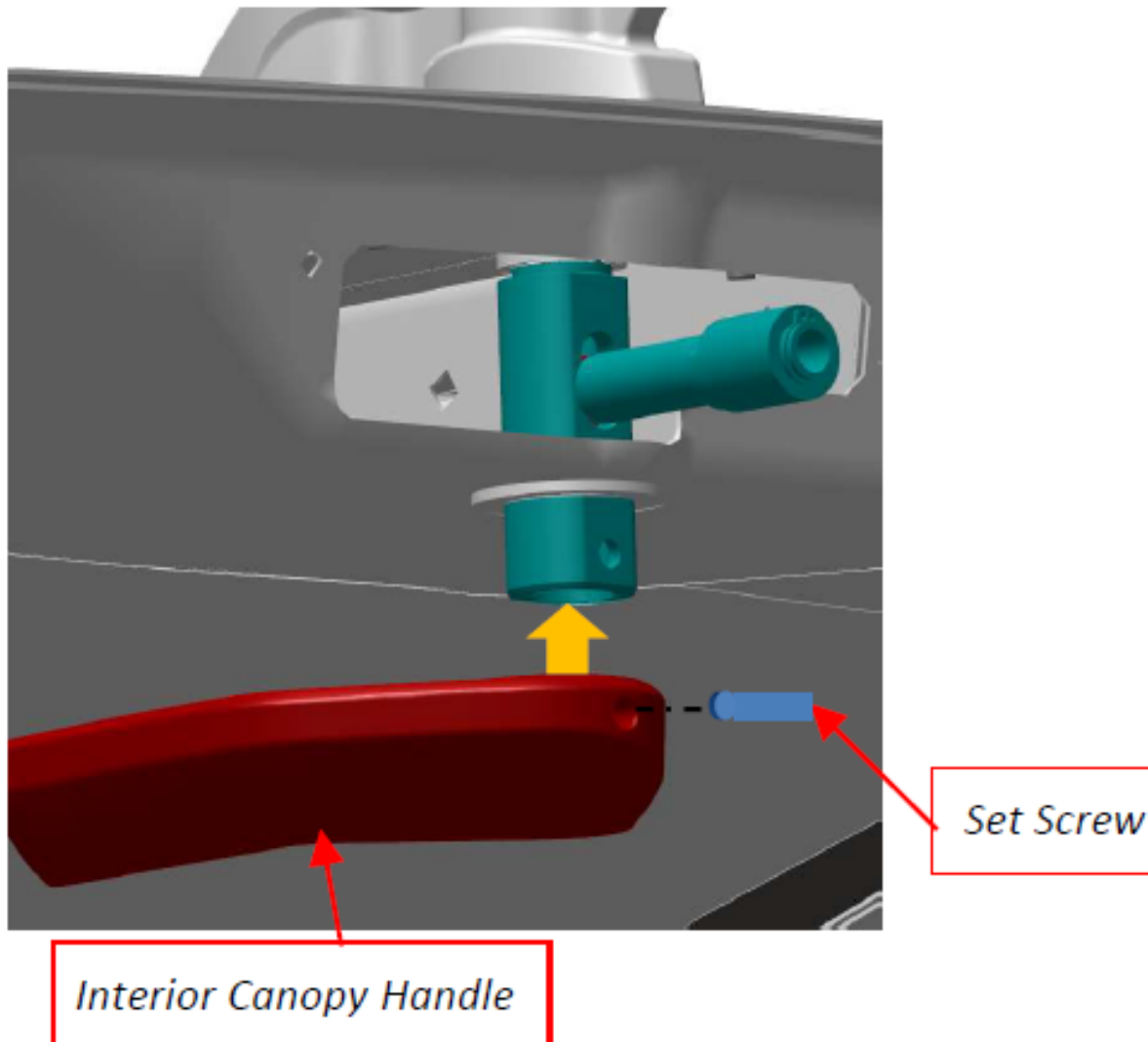
*Figure 3 Interior Latch Handle***Snap Ring Inspection/Repair**

1. While seated in the cockpit, inspect the inside of the canopy latch shaft for proper installation of the retaining ring.
  - a. See Figure 4
2. Ensure the retaining ring is seated in the inner groove of the latch shaft
  - a. See Figure 5

**SERVICE BULLETIN**

SB-101722-D

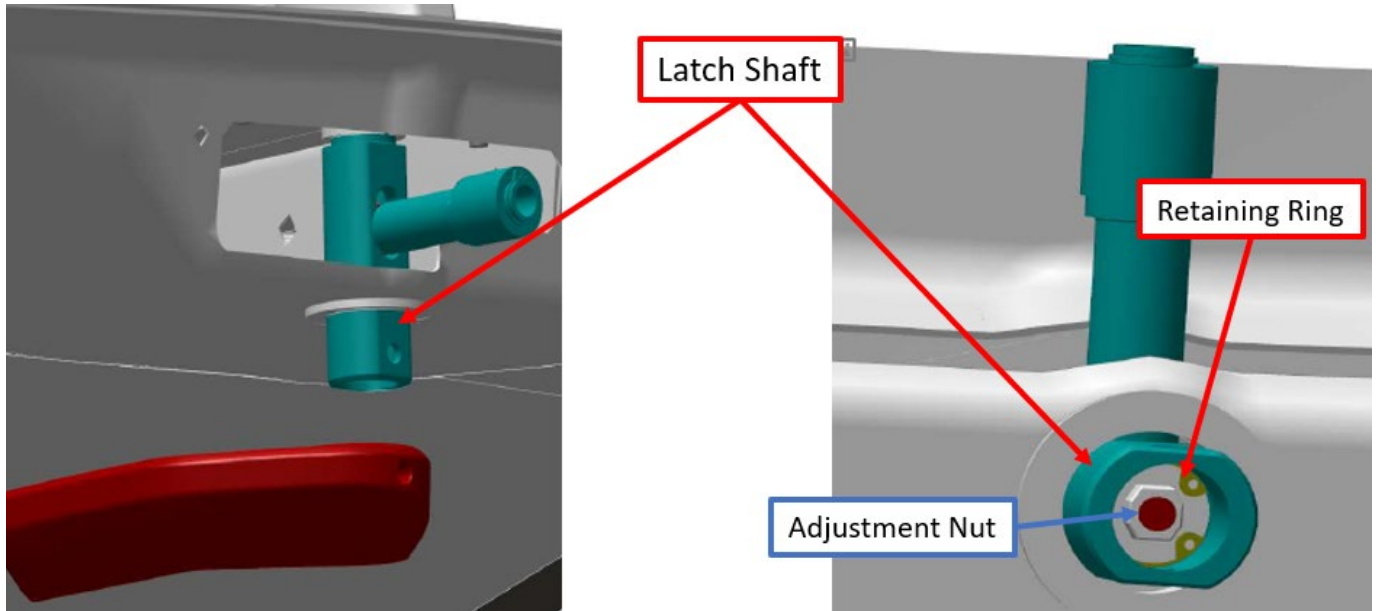
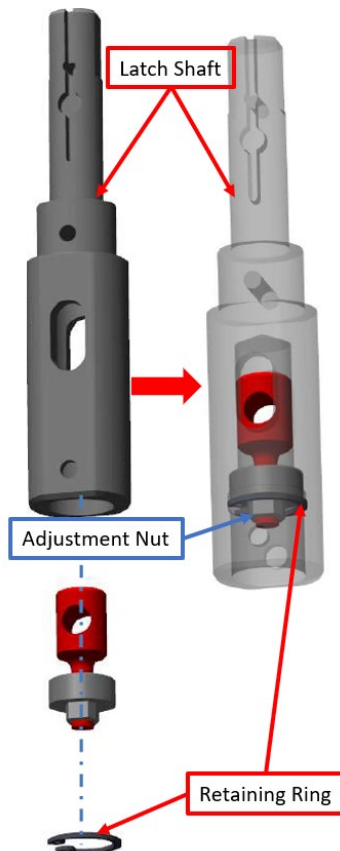
*Figure 4 Latch Shaft and Retaining Ring**Figure 5 Canopy Latch Shaft Retaining Ring*

**SERVICE BULLETIN****SB-101722-D**

3. If the retaining ring is not properly seated into position:
  - a. With needle nose pliers, carefully push the retaining ring back into position by firmly pushing up on the retaining ring until it clicks/ snaps into place.
  - b. If Unable to confidently seat snap ring into place, loosen the striker latch arm to allow smooth up and down adjustments (see Figure 6)

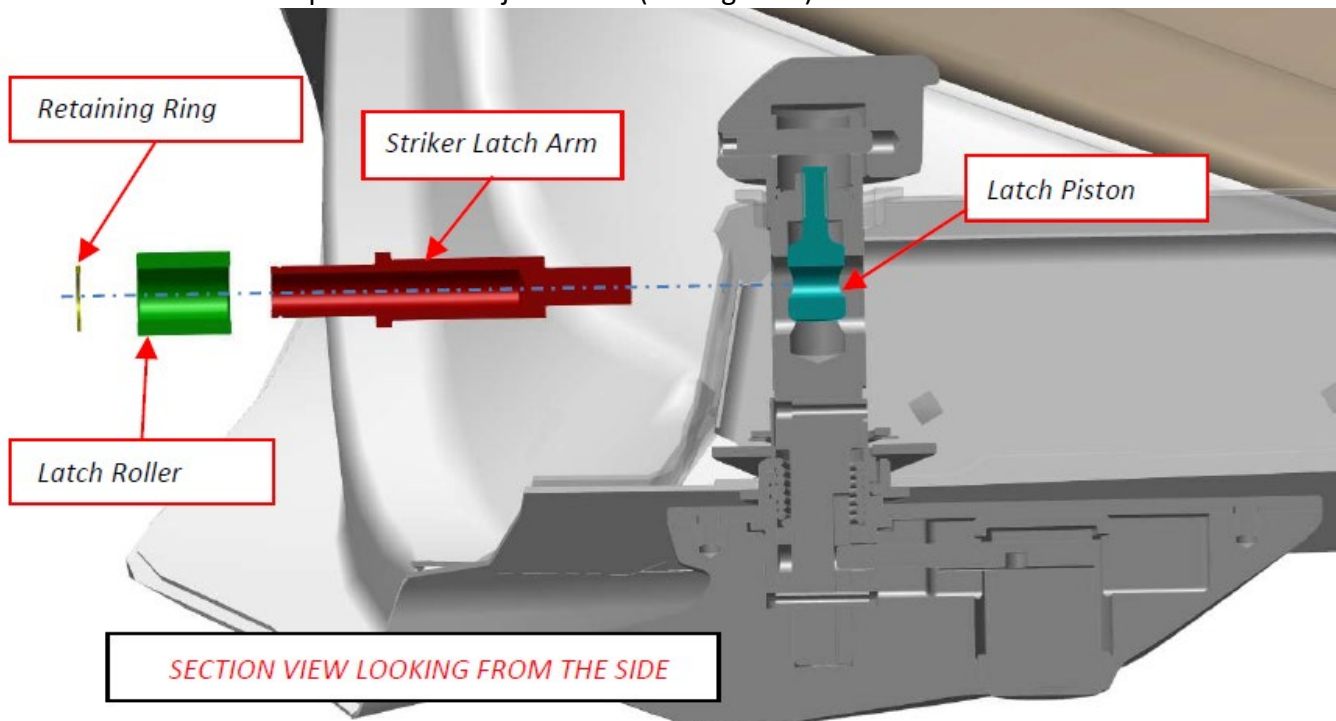
*Figure 6 Striker Latch Arm*

- c. Turn the adjustment nut clockwise/ counterclockwise to move the latch piston up or down to allow for the snap ring to confidently be seated in the snap ring groove.

**Canopy Latch Torque Inspection**

1. On the canopy latch shaft, use a force gauge or tool ITL002660 adapter and torque wrench (see Figure 8) to check the torque of the canopy latch mechanism.
  - a. 20 to 35 in lb to open canopy
  - b. 25 MAX in lb to close canopy
  - c. See Figure 7

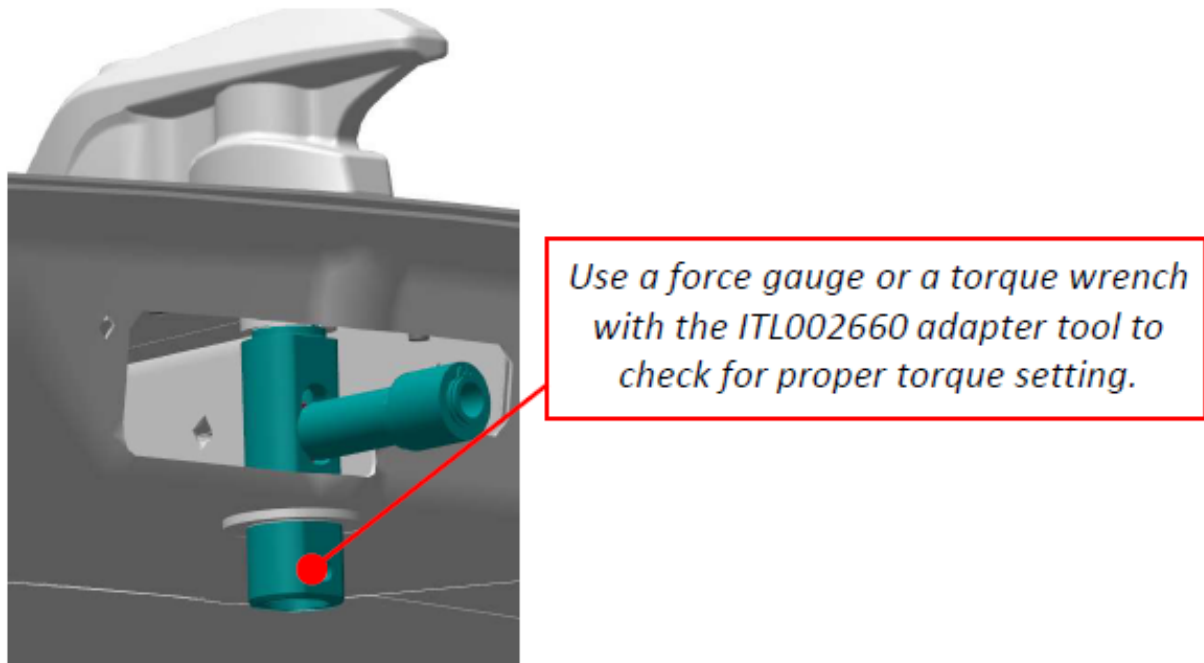
**SERVICE BULLETIN****SB-101722-D***Figure 7 Torque Check on Canopy Latch**Figure 8 ITL Torque Tool for Torque Wrench*

2. If the torque measurements are not within limits proceed with Canopy Latch Adjustment.

**Canopy Latch Adjustment**

1. Slightly loosen striker arm to allow for smooth up and down adjustments
2. With the canopy closed and canopy latch closed, turn the adjustment nut inside the canopy latch to adjust the torque required to open and closed the canopy latch.
  - a. See Figures 9 and 10

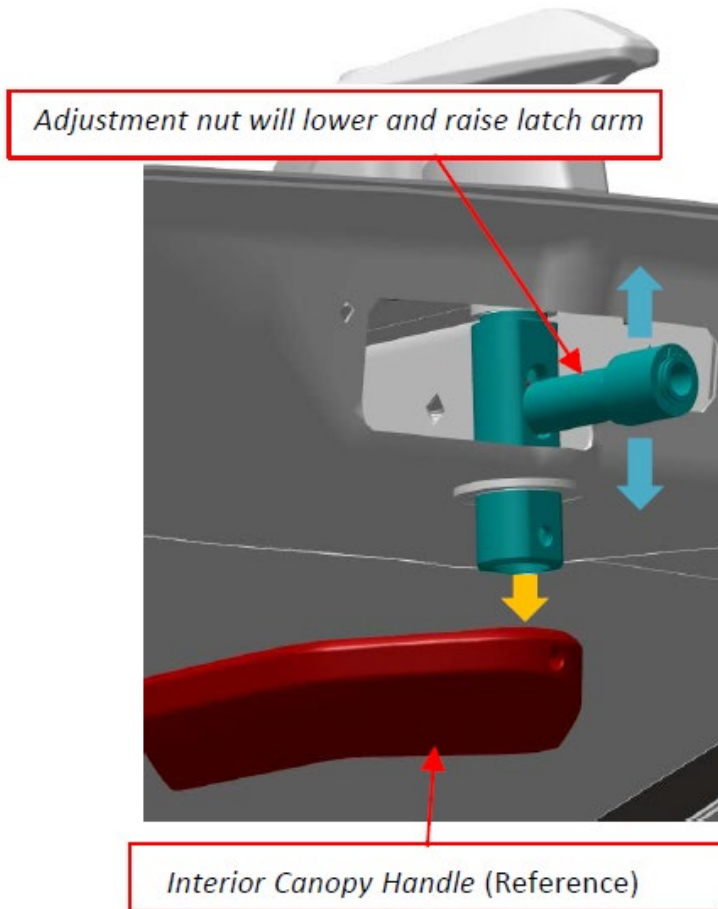
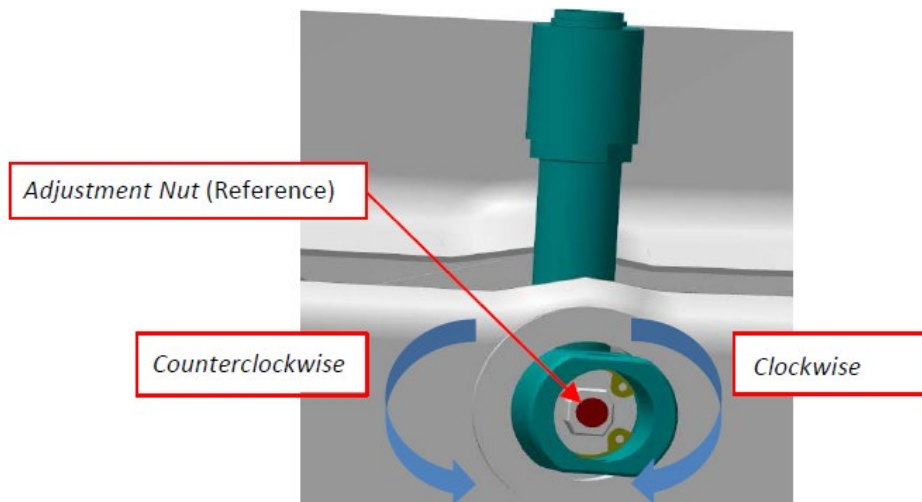

**SERVICE BULLETIN****SB-101722-D***Figure 9 Canopy Latch Adjustment**Figure 10 Adjusting the Canopy Latch*



## SERVICE BULLETIN

### SB-101722-D

3. On the canopy latch shaft, use a force gauge or tool ITL002660 adapter and torque wrench (see Figure 8) to check the torque of the canopy latch mechanism.
  - a. 20 to 35 in-lb to open canopy
  - b. Verify that the close force is no more than 25 in-lb to close canopy
  - c. See Figure 11

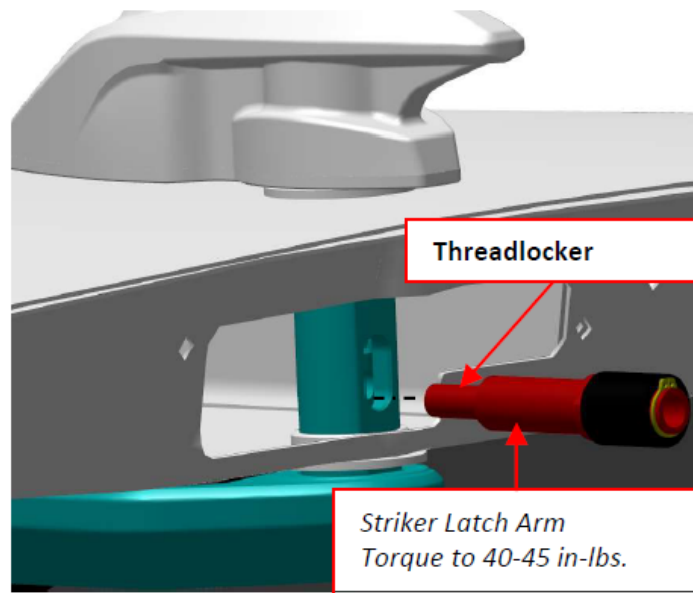

Figure 11 Canopy Torque Adjustment

4. Torque Striker Latch Arm to 40-45 in-lb
  - a. See Figure 12

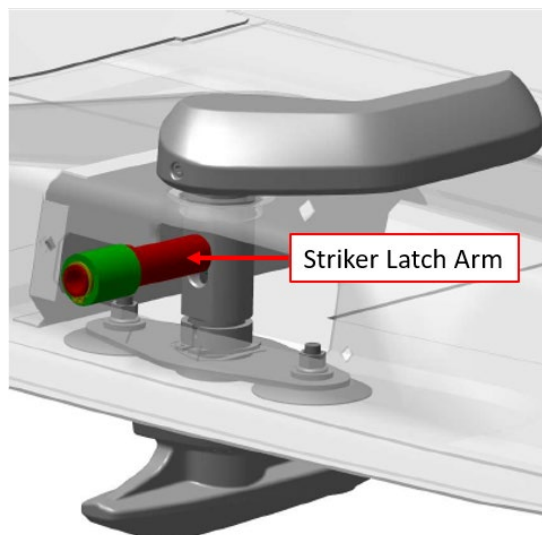

Figure 12 Striker Latch Arm



2141 ICON Way, Suite 100, Vacaville, CA 95688 - Tel: 707.564.4000 – [www.iconaircraft.com](http://www.iconaircraft.com)

## SERVICE BULLETIN

SB-101722-D

5. Validate the Canopy Latch torque after the latch striker arm is torqued to ensure nothing has changed
6. Install the canopy latch handle by inserting the handle over the canopy latch shaft and installing the set screw.
  - a. Apply Loctite 243 to the set screw
  - b. Torque set screw to 2-4 in-lb.
  - c. See Figure 3
7. As needed, refer to the latest revision of SL-072224 for application of sealant over screw heads shown in Figure 2 for leak mitigation.

### Make the following logbook entry:

"I hereby certify the repair and/or alteration has been completed in accordance with this Service Bulletin and all the referenced documents. Potentially unclear procedures have been clarified with the Aircraft OEM. No issues were observed that might hinder return to service.

The corrective action of Service Bulletin (SB-101722-D) has been complied with (ref. FAA Exemption 10829C)".

If you have questions, comments, or concerns about this Service Bulletin and/or if you are no longer owner/operator of this aircraft, please forward this information to the present owner/operator and notify ICON Aircraft at:

ICON Aircraft  
2141 ICON Way, Suite 100  
Vacaville, CA 95688  
(707) 564-4000

[support@iconaircraft.com](mailto:support@iconaircraft.com)

Please include the aircraft registration number, serial number, your name, and if known the contact information of the new owner/operator.